

WAREHOUSE DATA SHEET

COMPANY _____

ADDRESS _____

PHONE _____

ACTIVITY _____

LOAD DIMENSIONS

	L	P	H	Weight	%
Type 1					
Type 2					
Type 3					
Typo 4					

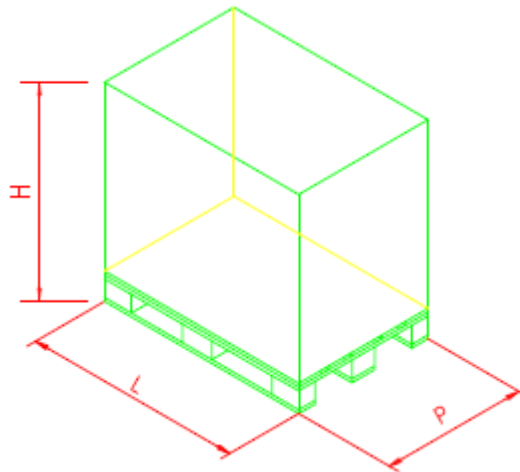

PALLET TYPE

	L	P	H	Lato inf.
Type 1				
Type 2				
Type 3				
Type 4				

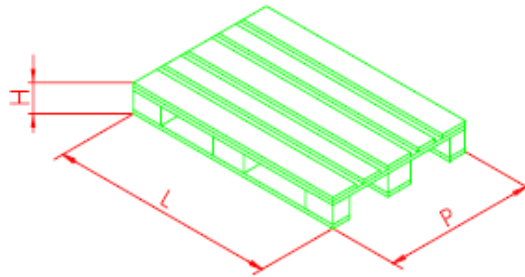

BOXES DIMENSIONS

	L	P	H/h	Weight	%
Type 1					
Type 2					
Type 3					
Type 4					

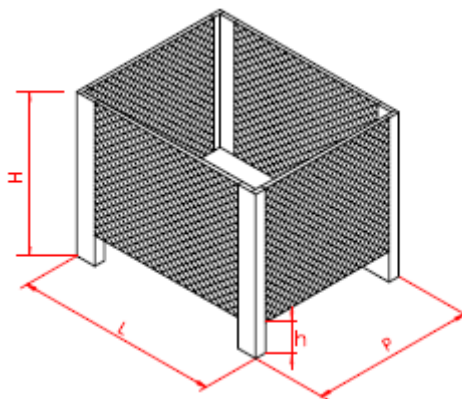



WAREHOUSE INFORMATIONS
(check the box)

	EXISTING		NEW BUILDING
	BEARING SELF		NOT BEARING SELF

WAREHOUSE DIMENSIONS

Length	mm
Width	mm
Useful height available	mm
Total Height	mm

NOTE: Please, joint the plan drawing of the available area, possibly in DWG format

CAPACITY REQUIRED
 (fill the box)

Number of loads entering warehouse per day	
Number of loads coming our from warehouse per day	
Load packed	<input type="checkbox"/> yes <input type="checkbox"/> not
Shift per day	
Number of articles in warehouse	
Working day per year	
Load capacity required in the warehouse	
Bar coded loads	<input type="checkbox"/> yes <input type="checkbox"/> not

Picking	<input type="checkbox"/> Sì <input type="checkbox"/> No
Pallet out (for Picking)	
N° boxes out per day (for Picking)	
Average boxes for each pick	
Number of references each order	
Maximum of orders/day	
Average of orders/day	
Bar code on boxes (if yes please attached label photo or label scan)	<input type="checkbox"/> Sì <input type="checkbox"/> No



OTHER USEFUL INFORMATIONS
(to be indicated on the drawing plan)

Entering point in the warehouse

Exit point from warehouse